



SERIE NP

Manometri a molla tubolare in esecuzione standard

- ◆ elemento manometrico in lega di rame;
- ◆ DN 40 - 50 - 63 - 80 - 100;
- ◆ campi di misura compresi fra -1 e 400 bar.

NP SERIES

Standard Bourdon tube pressure gauges

- ◆ copper alloy pressure element assembly;
- ◆ NS 40 - 50 - 63 - 80 - 100;
- ◆ ranges included between -1 and 400 bar.



Tabella NP 1 Modelli previsti e tipo di custodia			Table NP 1 Available models and casing type			
DN \ NP	301		304	305	306	
40	FK XK		FF	FF	FK	XK
50	FK XK		FF	FF	FK	XK
63	FK XK		FF	FF	FK	XK
80	FF		FF	FF	FF	
100	FF		FF	FF	FF	

<p>Legenda:</p> <p>FF = cassa di acciaio verniciato con fascia di copertura di acciaio verniciato o cromato e trasparente di vetro</p> <p>FK = cassa di acciaio verniciato e trasparente di materia plastica montato forzato</p> <p>XK = cassa di acciaio inossidabile e trasparente di materia plastica montato forzato</p>	<p>Caption:</p> <p>FF = painted steel case with painted or chromate steel slip-on ring and glass window</p> <p>FK = painted steel case and plastic snap-fit window</p> <p>XK = stainless steel case and plastic snap-fit window</p>
---	--

CARATTERISTICHE TECNICHE

- **Diametri nominali**
- 40, 50, 63, 80 e 100.
- **Custodia**
- vedere tabella NP 1.
- **Trasparente**
- vedere tabella NP 1.
- **Attacco di pressione (secondo EN 837-1)**
- di ottone con filettatura Gas (BSP), Gas conico (BSPT) o NPT secondo la quota F delle tabelle NP, oppure solo su richiesta, diverse da quelle indicate.

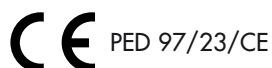
TECHNICAL FEATURES

- **Nominal sizes**
- 40, 50, 63, 80 and 100.
- **Casing**
- see table NP 1.
- **Window**
- see table NP 1.
- **Pressure connection (according to EN 837-1)**
- brass with Gas (BSP), BSPT or NPT thread as F dimension shown in NP tables, otherwise only on request, different from those indicated.



• **Elemento sensibile**

- di bronzo fosforoso.

• **Saldatura dell'elemento manometrico**

- in lega di stagno;
- in lega di stagno/argento per temperature > a 65°C e/o per pressioni > a 60 bar.

• **Movimento**

- di ottone.

• **Campi di scala
(secondo EN 837-1)**

o **Campi di numerazione:**

- manometri: 0 ÷ 1; 0 ÷ 1,6; 0 ÷ 2,5; 0 ÷ 4; 0 ÷ 6;
0 ÷ 10; 0 ÷ 16; 0 ÷ 25; 0 ÷ 40; 0 ÷ 60; 0 ÷ 100;
0 ÷ 160; 0 ÷ 250; 0 ÷ 400;
- vuotometri: -1 ÷ 0;
- manovuotometri: -1 ÷ 0,6; -1 ÷ 1,5; -1 ÷ 3; -1 ÷ 5;
-1 ÷ 9; -1 ÷ 15; -1 ÷ 24;
(divisioni secondo tabella C1 a pag. P08)
- altri campi non normalizzati per singola o doppia scala (su richiesta).

o **Unità di pressione:**

- bar, kPa, MPa, kg/cm² e psi per singola o doppia scala.

o **Angolo della scala:**

- 270 °.

nota: la pressione di esercizio, se costante, deve essere compresa fra 1/10 e 3/4 circa del valore di fondo scala; per pressioni variabili o pulsanti è opportuno adottare gli strumenti della serie SP a riempimento di liquido.

• **Sovrappressione**

- non ammessa.

• **Indice**

- di acciaio brunito con virola fissa.

• **Quadrante**

- di alluminio con scale graduate e scritte in nero indelebile su fondo bianco.

• **Precisione**

(secondo EN 837-1)

- classe 1,6 (± 1,6% riferito al valore di fondo scala).

• **Temperatura ambiente**

--10 ÷ +60 °C.

• **Temperatura di utilizzo**

- 0 ÷ + 65 °C con saldatura in lega di stagno;
- -10 ÷ + 120 °C con saldatura in lega di stagno/argento.

• **Pressure element**

- phosphor bronze.

• **Welding**

- tin alloy;
- tin/silver alloy for temperatures > 65°C and/or pressures > 60 bar.

• **Movement**

- brass.

• **Ranges
(according to EN 837-1)**

o **Graduation:**

- pressure gauges: 0 ÷ 1; 0 ÷ 1,6; 0 ÷ 2,5; 0 ÷ 4;
0 ÷ 6; 0 ÷ 10; 0 ÷ 16; 0 ÷ 25; 0 ÷ 40; 0 ÷ 60;
0 ÷ 100; 0 ÷ 160; 0 ÷ 250; 0 ÷ 400;
- vacuum gauges: -1 ÷ 0;
- compound gauges: -1 ÷ 0,6; -1 ÷ 1,5; -1 ÷ 3; -1 ÷ 5;
-1 ÷ 9; -1 ÷ 15; -1 ÷ 24;
(divisions as per table C1 at page P08)
- other graduations not normalized for single or double range (on request).

o **Unit of pressure:**

- bar, kPa, MPa, kg/cm² and psi for single or double scale.

o **Scale angle:**

- 270 °.

note: working pressure, if constant, has to be included between 1/10 and about 3/4 of full scale value; for fluctuating or pulsating pressures it is suitable to choose a liquid filled instruments of SP series.

• **Over-pressure**

- not allowed.

• **Pointer**

- burnished steel - not adjustable.

• **Dial**

- white aluminium with black figures.

• **Accuracy**

(according to EN 837-1)

- class 1,6 (± 1,6% of full scale deflection).

• **Ambient temperature**

--10 ÷ +60 °C.

• **Operating temperature**

- 0 ÷ + 65 °C with tin alloy welding;
- -10 ÷ +120 °C with tin/silver alloy welding.

ADATTABILITÀ

- **Accessori
(vedere la serie AM)**

APPLICATIONS

- **Accessories
(see AM series)**



VARIANTI

- **Indice rosso regolabile sul trasparente**
(sigla di identificazione V13)
- **Indice rosso sul quadrante**
(sigla di identificazione V14)
- **Elemento di strozzatura**
applicabile all'attacco di pressione per ridurre la velocità di ingresso del fluido di processo nello strumento.
(sigla di identificazione V26)

OPTIONS

- **Adjustable red pointer on the window**
(identification V13)
- **Red pointer on the dial**
(identification V14)
- **Restrictor**
applicable to pressure connection to reduce the process fluid entry speed into the instrument.
(identification V26)

DOCUMENTAZIONE

- **Documenti complementari**
 - o attestato di conformità all'ordinazione EN 10204-2.2.
 - o dichiarazione PED.

DOCUMENTATION

- **Complementary documents**
 - o certificate of compliance with the order EN 10204-2.2.
 - o PED declaration.

COME ORDINARE

HOW TO ORDER

Model	Options	Nominal size	Connection	Range																								
NP 301-FF NP 301-FK NP 301-XK NP 304-FF NP 305-FF NP 306-FF NP 306-FK NP 306-XK	V13 V14 V26	DN 40 DN 50 DN 63 DN 80 DN 100	1/8 Gas 1/8 Gas con. 1/8 NPT 1/4 Gas 1/4 Gas con. 1/4 NPT 1/2 Gas 1/2 Gas con. 1/2 NPT Others	<table border="0"> <tr> <td></td> <td></td> <td>-1 ÷ 0 bar</td> </tr> <tr> <td>0 ÷ 1 bar</td> <td>0 ÷ 25 bar</td> <td>-1 ÷ 0,6 bar</td> </tr> <tr> <td>0 ÷ 1,6 bar</td> <td>0 ÷ 40 bar</td> <td>-1 ÷ 1,5 bar</td> </tr> <tr> <td>0 ÷ 2,5 bar</td> <td>0 ÷ 60 bar</td> <td>-1 ÷ 3 bar</td> </tr> <tr> <td>0 ÷ 4 bar</td> <td>0 ÷ 100 bar</td> <td>-1 ÷ 5 bar</td> </tr> <tr> <td>0 ÷ 6 bar</td> <td>0 ÷ 160 bar</td> <td>-1 ÷ 9 bar</td> </tr> <tr> <td>0 ÷ 10 bar</td> <td>0 ÷ 250 bar</td> <td>-1 ÷ 15 bar</td> </tr> <tr> <td>0 ÷ 16 bar</td> <td>0 ÷ 400 bar</td> <td>-1 ÷ 24 bar</td> </tr> </table>			-1 ÷ 0 bar	0 ÷ 1 bar	0 ÷ 25 bar	-1 ÷ 0,6 bar	0 ÷ 1,6 bar	0 ÷ 40 bar	-1 ÷ 1,5 bar	0 ÷ 2,5 bar	0 ÷ 60 bar	-1 ÷ 3 bar	0 ÷ 4 bar	0 ÷ 100 bar	-1 ÷ 5 bar	0 ÷ 6 bar	0 ÷ 160 bar	-1 ÷ 9 bar	0 ÷ 10 bar	0 ÷ 250 bar	-1 ÷ 15 bar	0 ÷ 16 bar	0 ÷ 400 bar	-1 ÷ 24 bar
		-1 ÷ 0 bar																										
0 ÷ 1 bar	0 ÷ 25 bar	-1 ÷ 0,6 bar																										
0 ÷ 1,6 bar	0 ÷ 40 bar	-1 ÷ 1,5 bar																										
0 ÷ 2,5 bar	0 ÷ 60 bar	-1 ÷ 3 bar																										
0 ÷ 4 bar	0 ÷ 100 bar	-1 ÷ 5 bar																										
0 ÷ 6 bar	0 ÷ 160 bar	-1 ÷ 9 bar																										
0 ÷ 10 bar	0 ÷ 250 bar	-1 ÷ 15 bar																										
0 ÷ 16 bar	0 ÷ 400 bar	-1 ÷ 24 bar																										
EXAMPLE = NP 301-FF-V13 • DN 80 x 1/4 Gas • range 0 ÷ 16 bar																												



NP 301



Manometro con attacco radiale per montaggio diretto

Pressure gauge with bottom connection for local mounting

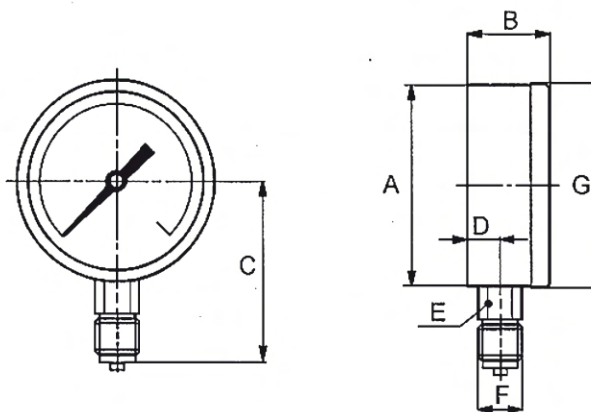

Table NP 301

DN	A	B	C	D	E	F	G	H	I	L	M	N	∅ fori 120°	PESO ~ kg
40	40	25	36	8,8	12	1/8	40							0,06
50	51	27	46	9,5	14	1/4	51							0,10
63	63	27	53	10	14	1/4	63							0,13
80	79	32	66	10	14	1/4	81							0,21
100	99	51	87	15	22	1/2	102							0,60

NP 304



Manometro con attacco posteriore per montaggio incassato e fissaggio con 3 fori

Pressure gauge with back connection for flush mounting with 3 fixing holes

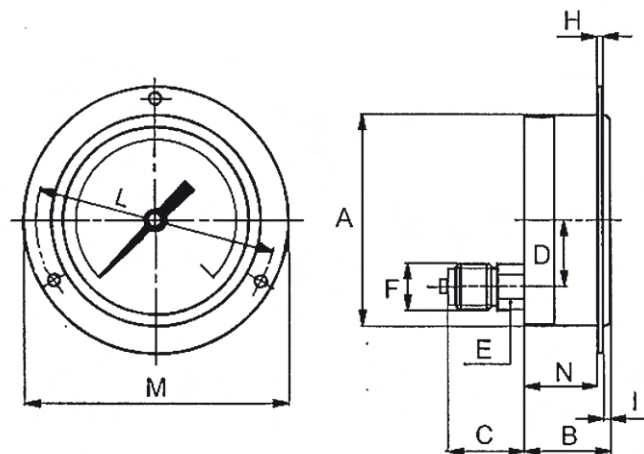
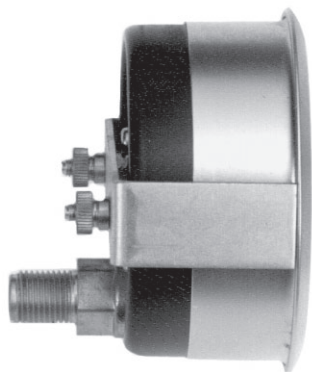

Table NP 304

DN	A	B	C	D	E	F	G	H	I	L	M	N	∅ fori 120°	PESO ~ kg
40	41	28	16	0	12	1/8		2	2	51	61	24	3,6	0,10
50	52	30	20	0	14	1/4		2	2	60	71	26	3,6	0,16
63	64	30	20	0	14	1/4		2	1,5	75	85	26,5	3,6	0,20
80	81	30	20	0	14	1/4		2	2,5	95	110	25,5	5	0,26
100	101	51	35	30	17	1/2		2,5	3,5	118	132	45	6	0,65



NP 305



Manometro con attacco posteriore per montaggio incassato e fissaggio con staffa

Pressure gauge with back connection for flush mounting with clamp fixing

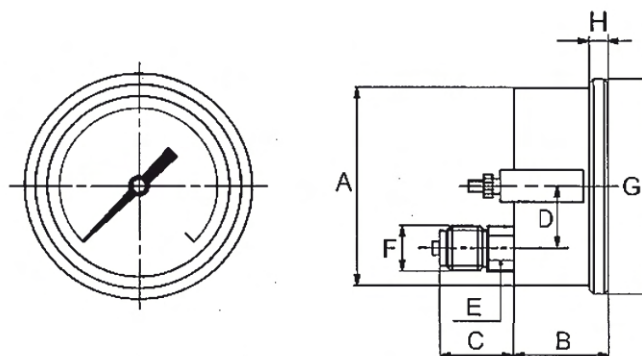

Table NP 305

DN	A	B	C	D	E	F	G	H	I	L	M	N	Ø fori 120°	PESO ~ kg
40	40	28	25	0	12	1/8	44	4,5						0,09
50	51	30	27	0	14	1/4	55	5,5						0,15
63	63	30	27	0	14	1/4	68	7						0,17
80	79	30	27	0	14	1/4	84	7						0,23
100	101	51	35	30	17	1/2	132	7						0,71

NP 306



Manometro con attacco posteriore per montaggio diretto

Pressure gauge with back connection for direct mounting

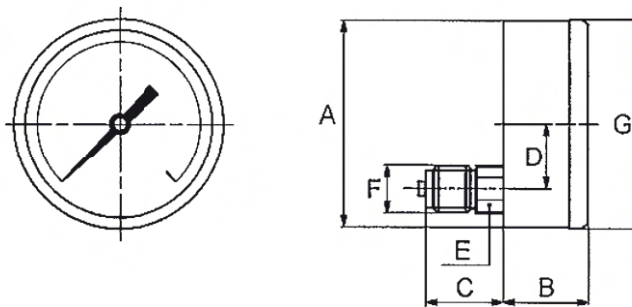

Table NP 306

DN	A	B	C	D	E	F	G	H	I	L	M	N	Ø fori 120°	PESO ~ kg
40	40	25	16	0	12	1/8	40							0,06
50	51	27	20	0	14	1/4	51							0,10
63	63	27	20	0	14	1/4	63							0,13
80	79	32	20	0	14	1/4	81							0,22
100	99	51	35	30	17	1/2	102							0,60

nota: i dati qui riportati non sono impegnativi ma suscettibili di eventuali modifiche in funzione di esigenze tecnico-commerciali
note: informations shown in this series may be changed at any time without prior notice